

**MERCEDES VITO
FROM 2004**

ELECTRIC STEP

7493-004

ELECTRIC STEP

MERCEDES VITO from 2004

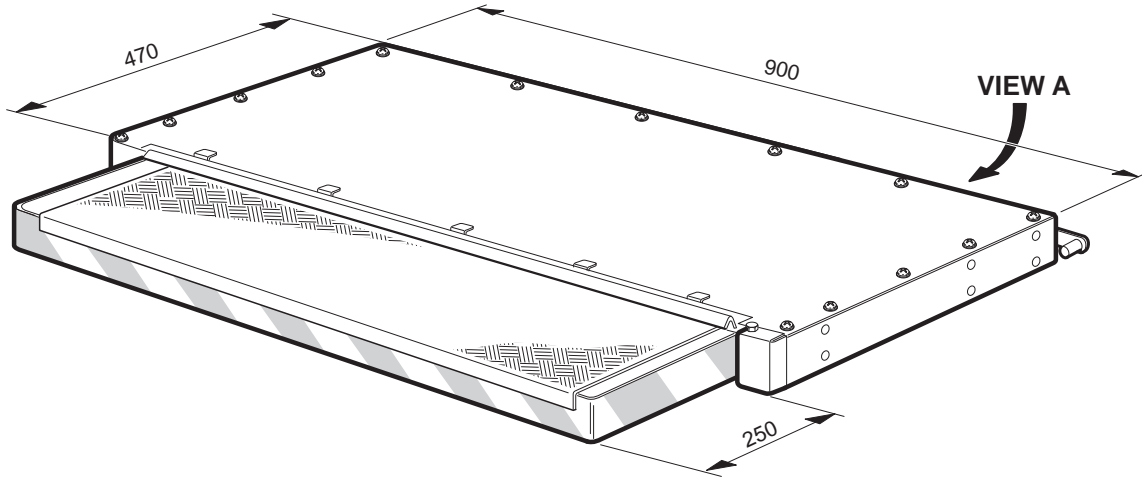

VIEW A

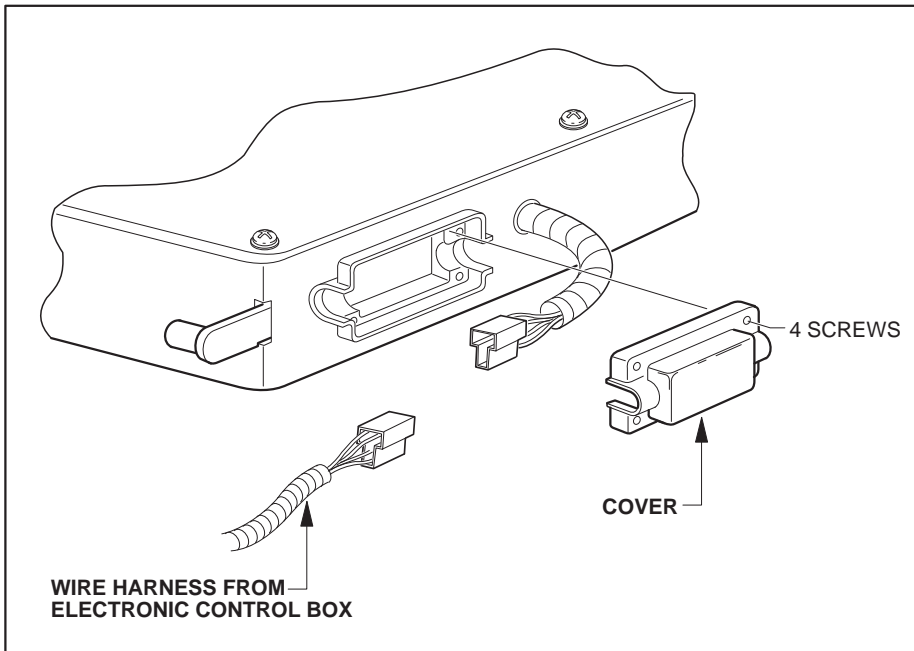

DISMANTLE PLASTIC COVER, CONNECT WIRE HARNESS FROM ELECTRONIC CONTROL BOX AND REINSTALL THE PLASTIC COVER.

ELECTRIC STEP

MERCEDES VITO

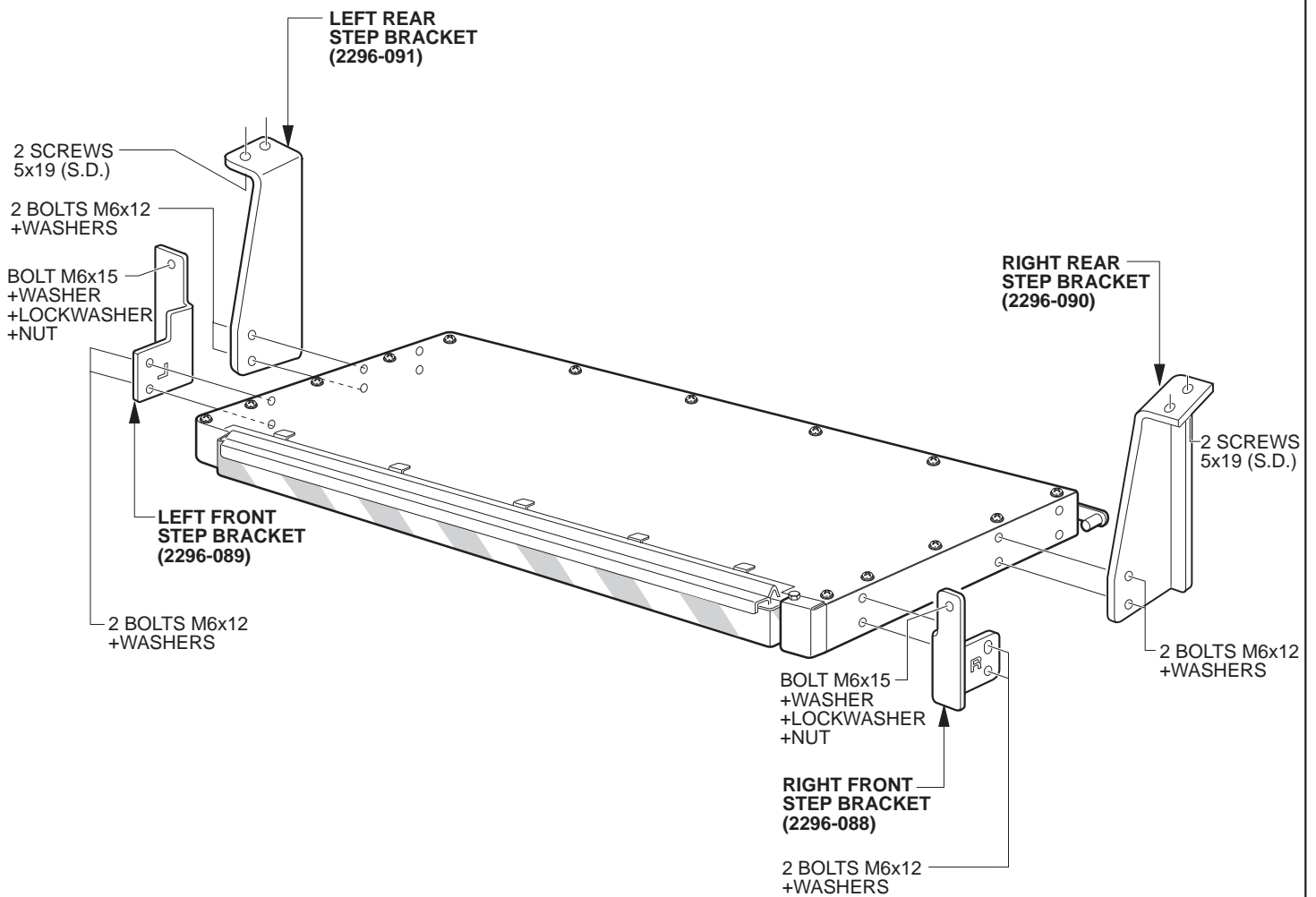
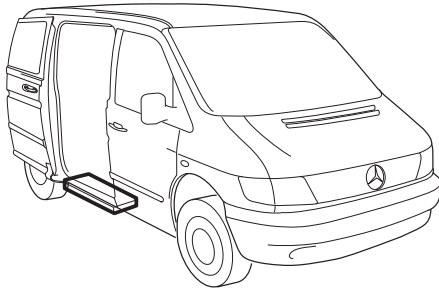

ELECTRIC STEP

MERCEDES VITO from 2004

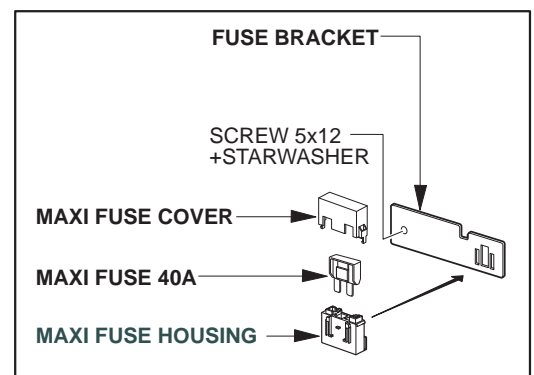
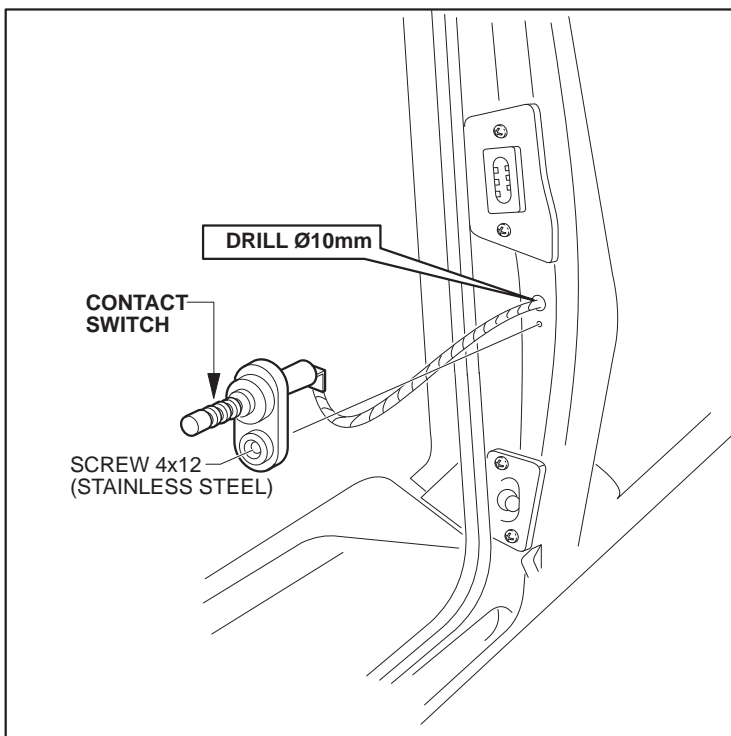
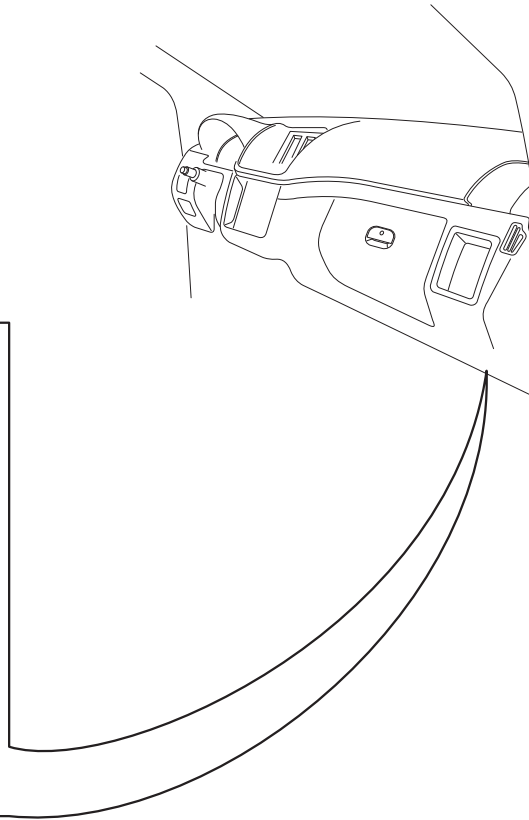
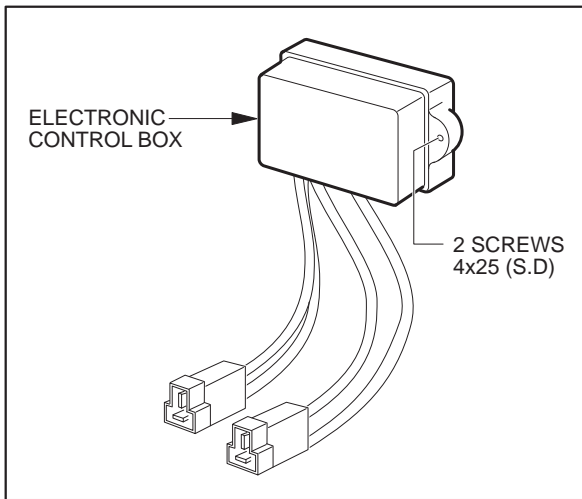

ELECTRIC STEP

WIRING DIAGRAM FOR VEHICLE WITHOUT ELECTRIC DOOR

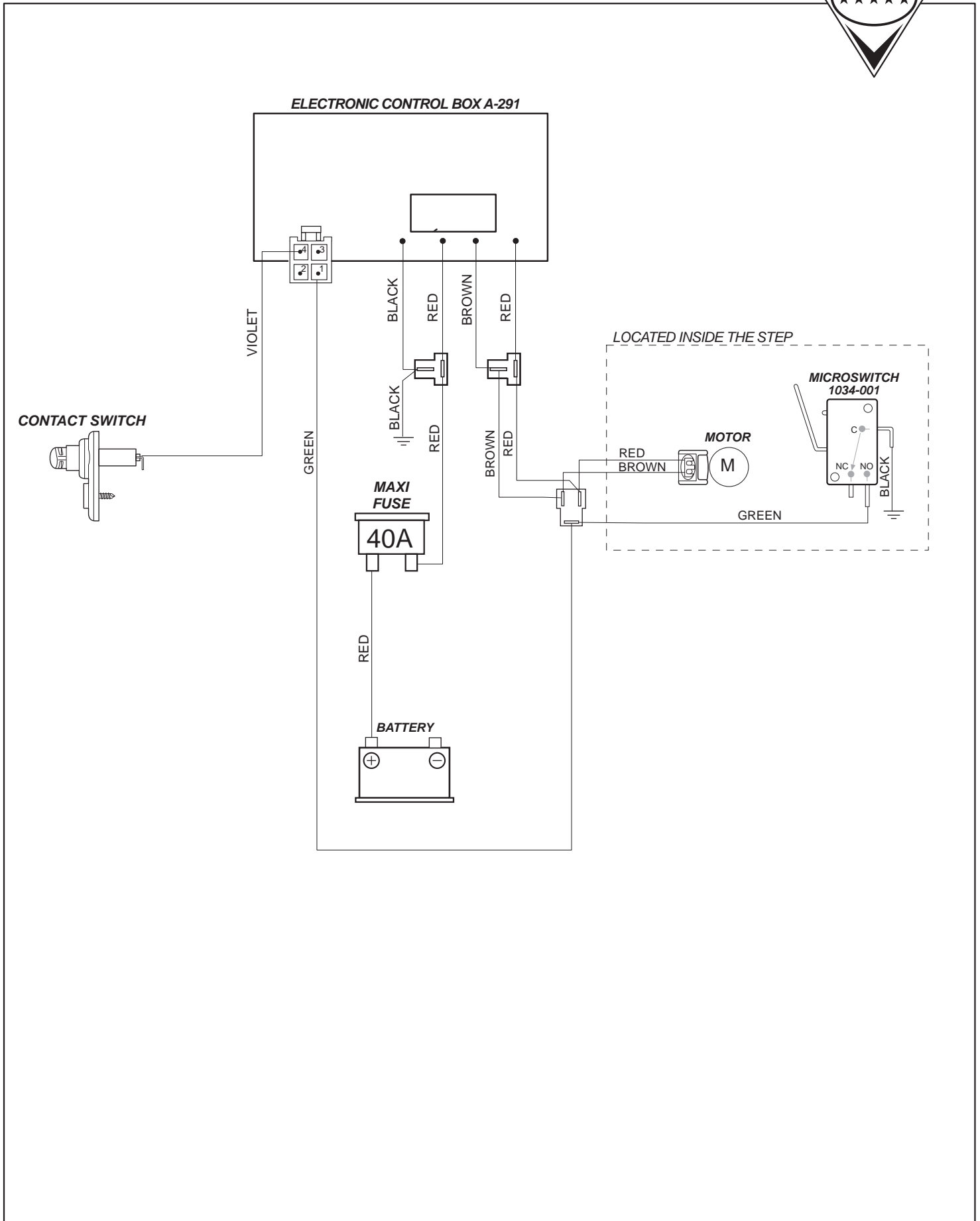

ELECTRIC STEP

WIRING DIAGRAM FOR VEHICLE WITH ELECTRIC DOOR

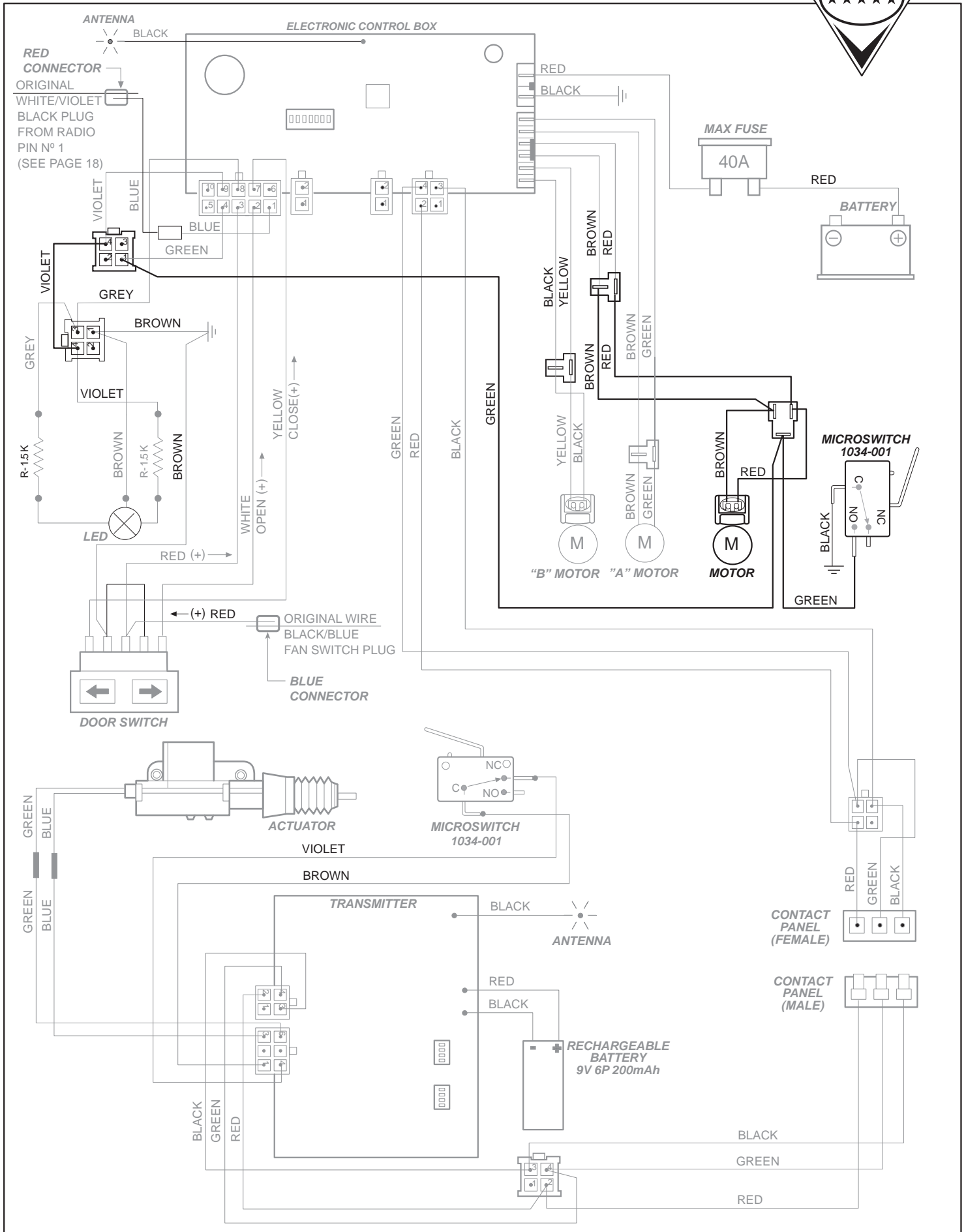

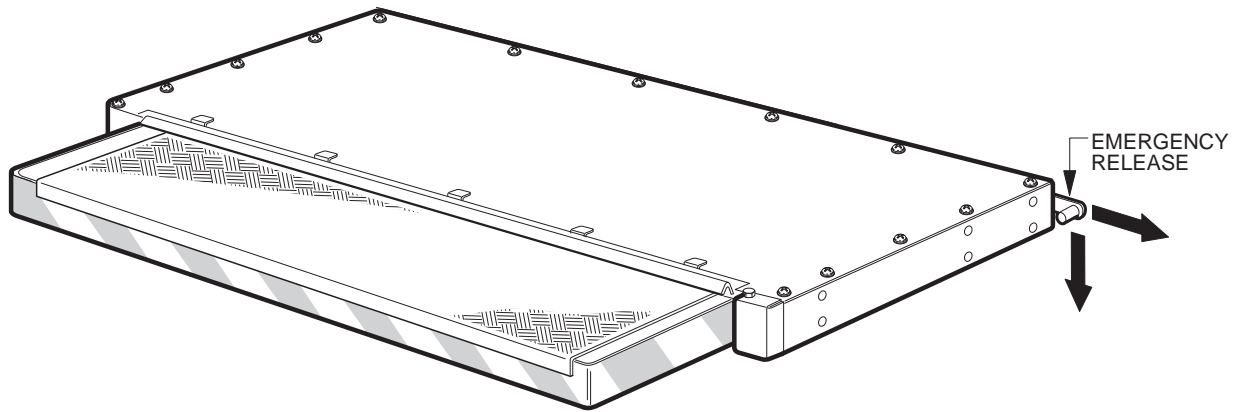

NOTE: IN CASE THE STEP IS STUCK AND DOES NOT RETURN TO IT'S HOUSING
BECAUSE OF ELECTRIC FAILURE PERFORM THE FOLLOWING PROCEDURE:

1. DISCONNECT THE WIRE HARNESS COMING FROM THE ELECTRONIC CONTROL BOX (SEE PAGE 1)
2. PULL THE LEVER TO ARROW'S DIRECTION.
3. MAKE SURE TO LOCK THE LEVER BY PUSHING LEVER DOWN.
4. PUSH STEP TO IT'S HOUSING.
5. RELEASE THE LEVER BY PULLING LEVER UP.